

PLAN VIEW

This is a non traffic-rated tank

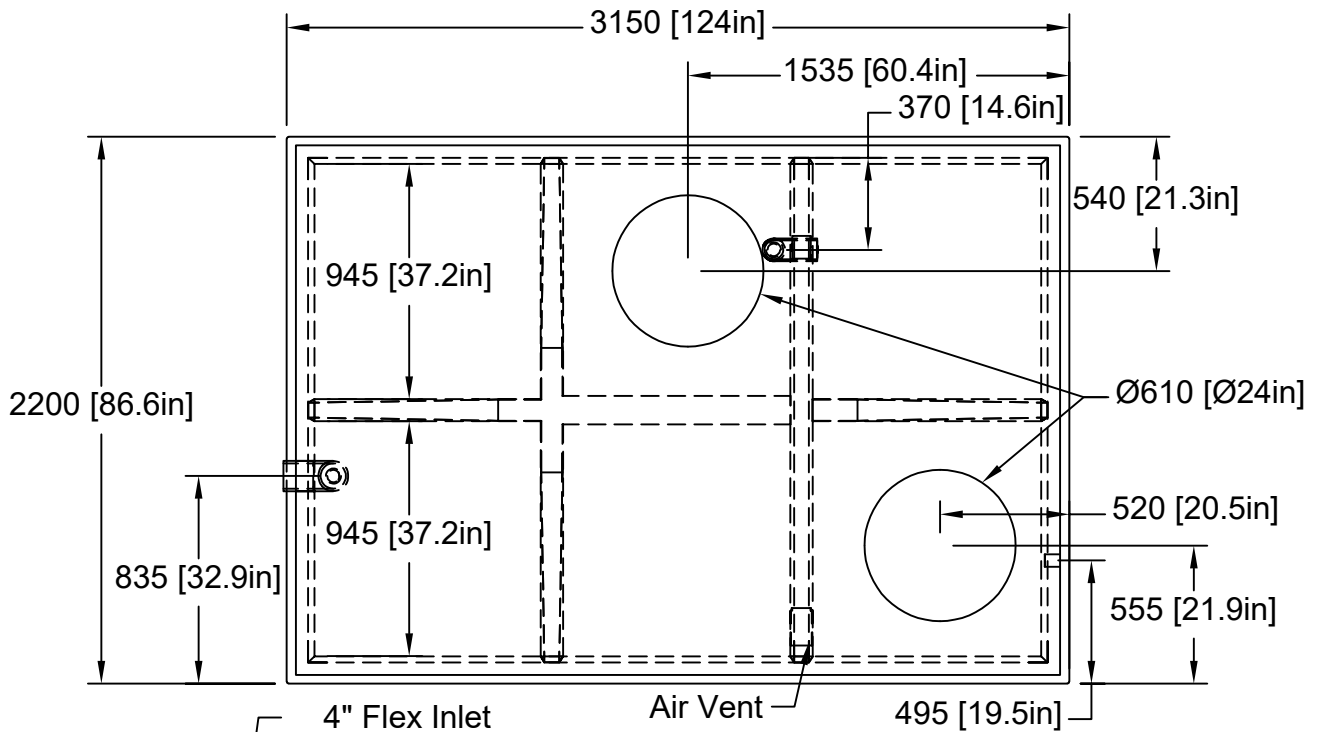

SIDE VIEW

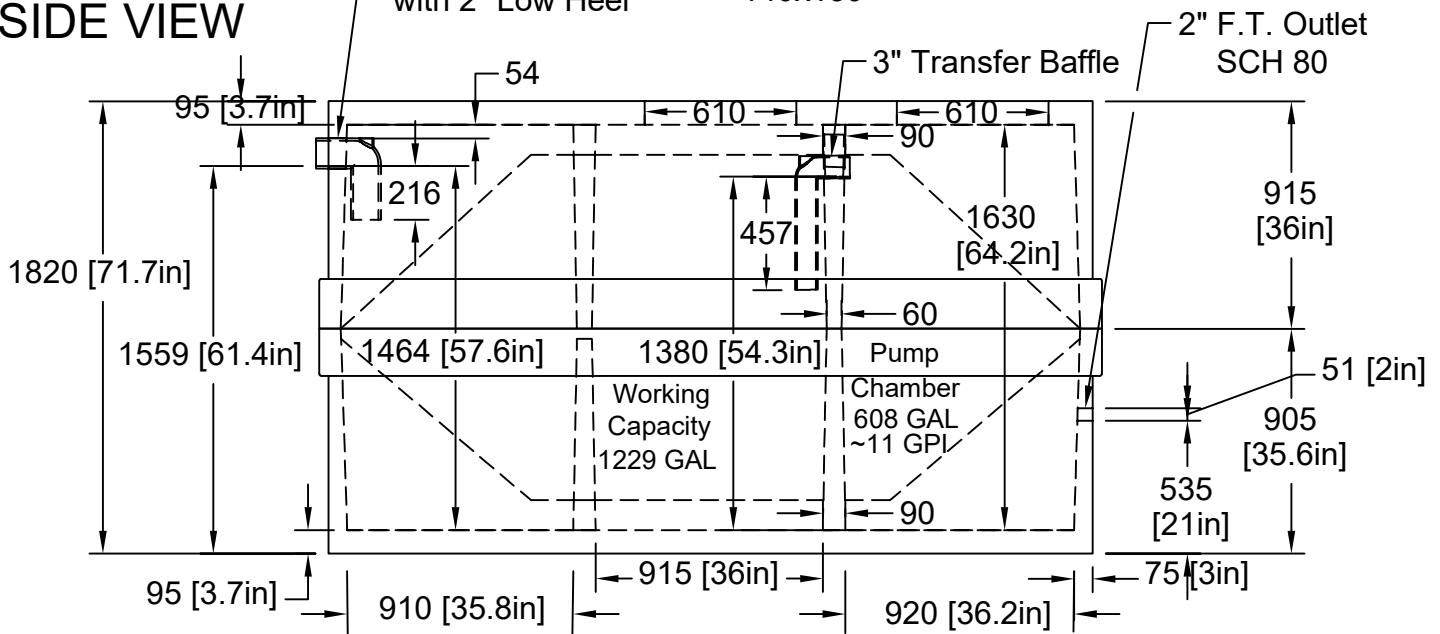

Note: Butyl Sealants must be applied at the joint of 2-piece tank

Date: 12/06/2022	#100 53251 Range Road 232 Sherwood Park, AB T8A 4V2	Type Septic Tank	
		Model P2000	
 TANKS-A-LOT onsite water and sewage solutions	p 780.472.8265 f 780.478.5699 tf 800.661.5667 info@tanks-a-lot.com www.tanks-a-lot.com	Configuration 2 Piece - 2 Manhole	
		Capacity: 1,837/1,229gal (8,351/5,591L)	
Earth Cover: 9'-9" (3m)		Weight: 18,000lbs (6.71T)	Revision: 4.0
Sheet Size: A (8.5"x11")		Scale: 1:30	Sheet 1/1
Drawn by: Joe Kaup			