

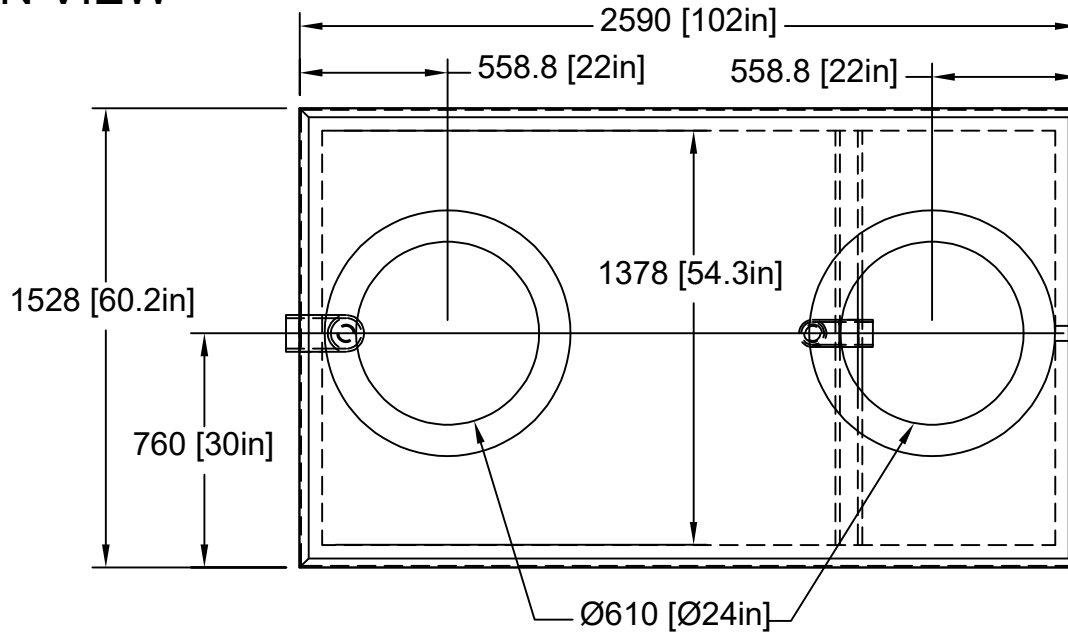

PLAN VIEW

This is a non traffic-rated tank

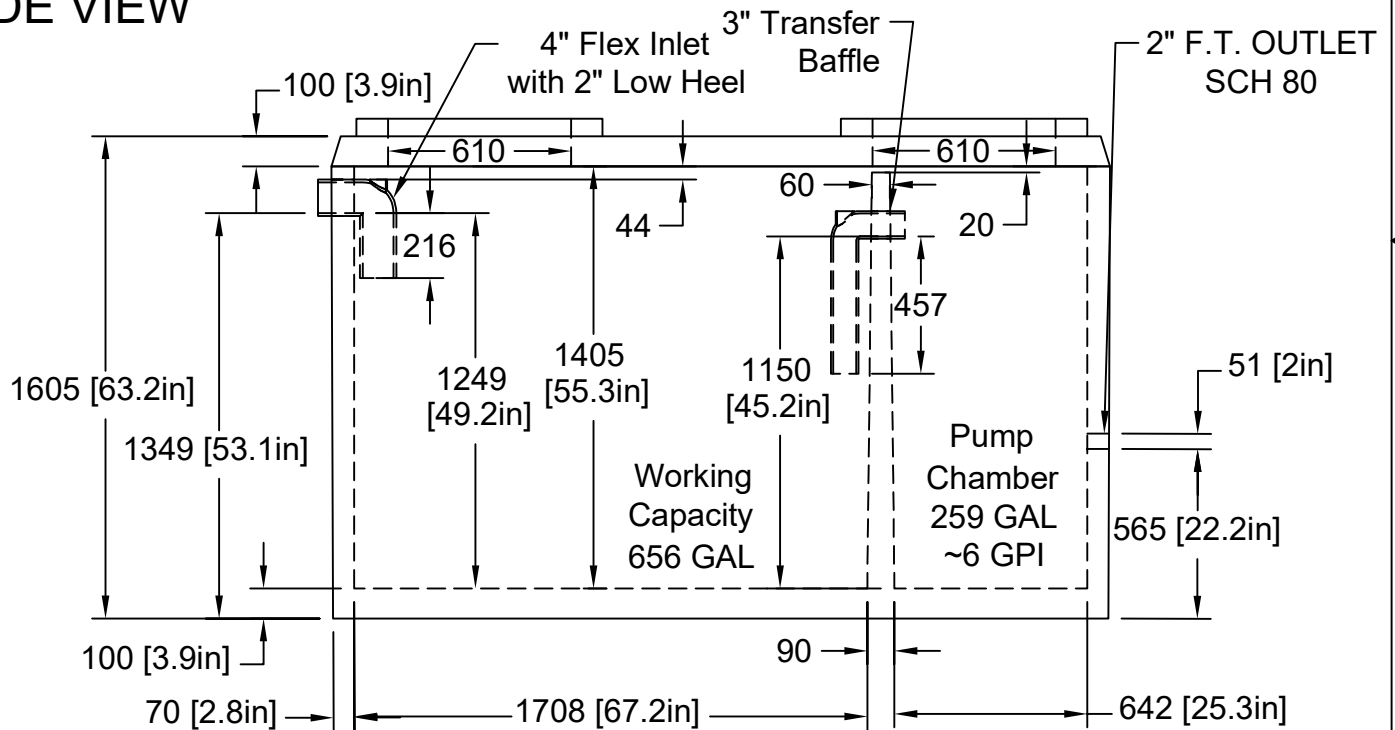

SIDE VIEW



Date: 12/06/2022	#100 53251 Range Road 232 Sherwood Park, AB T8A 4V2	Type Septic Tank		
	p 780.472.8265 f 780.478.5699 tf 800.661.5667 info@tanks-a-lot.com www.tanks-a-lot.com	Model P1020/2		
		Configuration 1 Piece - 2 Manhole		
		Capacity: 1,020/656gal (4,637/2,985L)		
Earth Cover: 7'-9" (2.37m)		Weight: 8,270lbs (3,751kg)	Revision: 4.0	
Sheet Size: A (8.5"x11")		Scale: 1:25	Sheet 1/1	
Drawn by: Joe Kaup				