

PLAN VIEW

This is a non traffic-rated tank

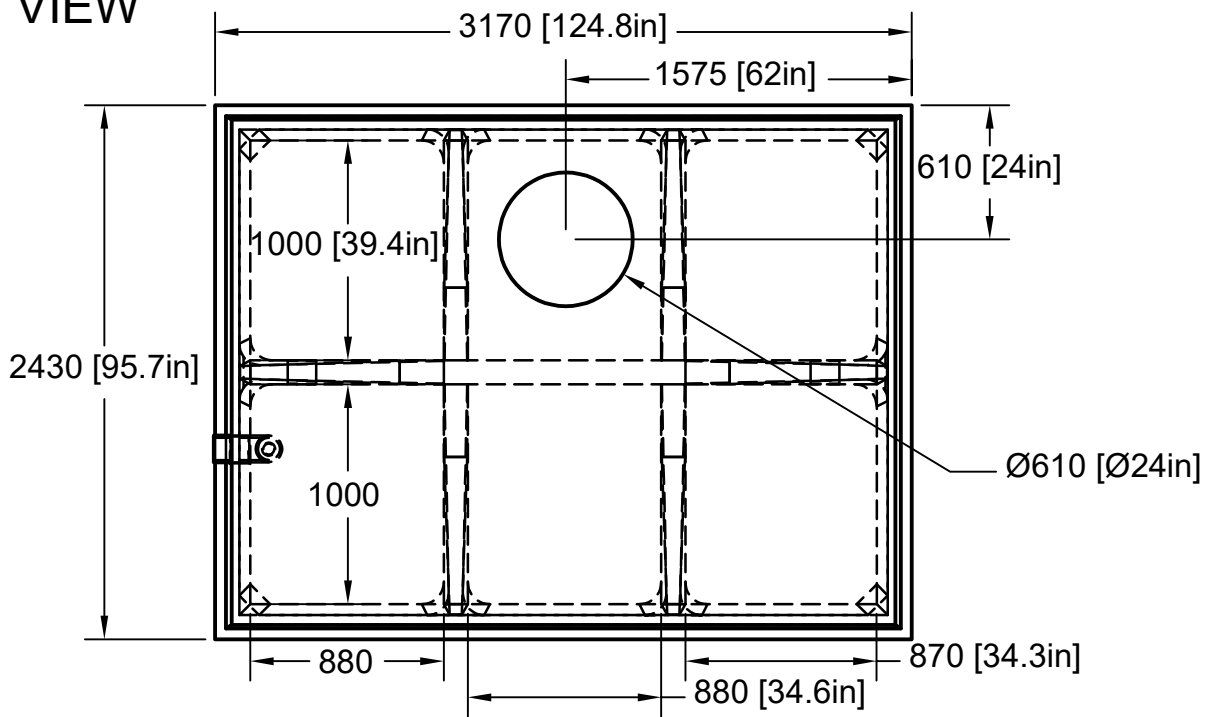

FRONT VIEW

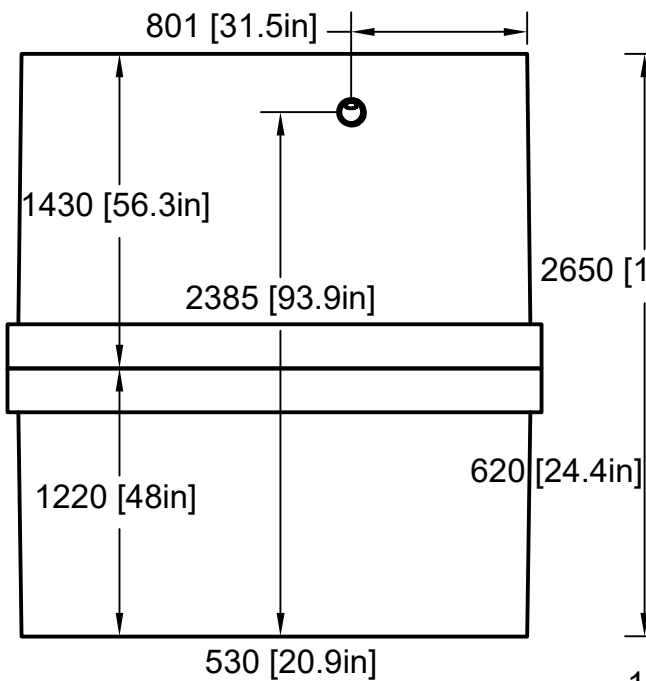

SIDE VIEW

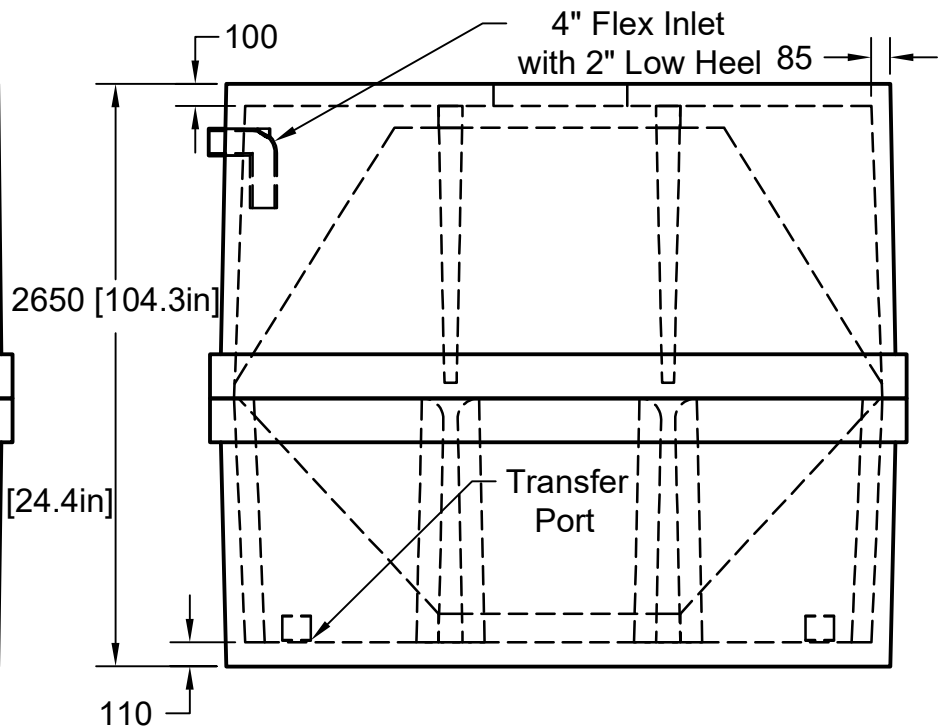

Date: 12/06/2022	#100 53251 RR 232 Sherwood Park, AB T8A 4V2	Type Holding Tank	
		Model H3400	
	p 780.472.8265 f 780.478.5699 tf 800.661.5667 info@tanks-a-lot.com www.tanks-a-lot.com	Configuration 2 Piece - 1 Manhole	
		Capacity: 3,400gal (15,456L)	
Earth Cover: 6'-6" (2.0m)	www.tanks-a-lot.com	Weight: 21,650lbs (9.820T)	Revision: 3.0
Sheet Size: A (8.5"x11")		Scale: 1:35	Sheet 1/1
Drawn by: Tristan Nelson			