

PLAN

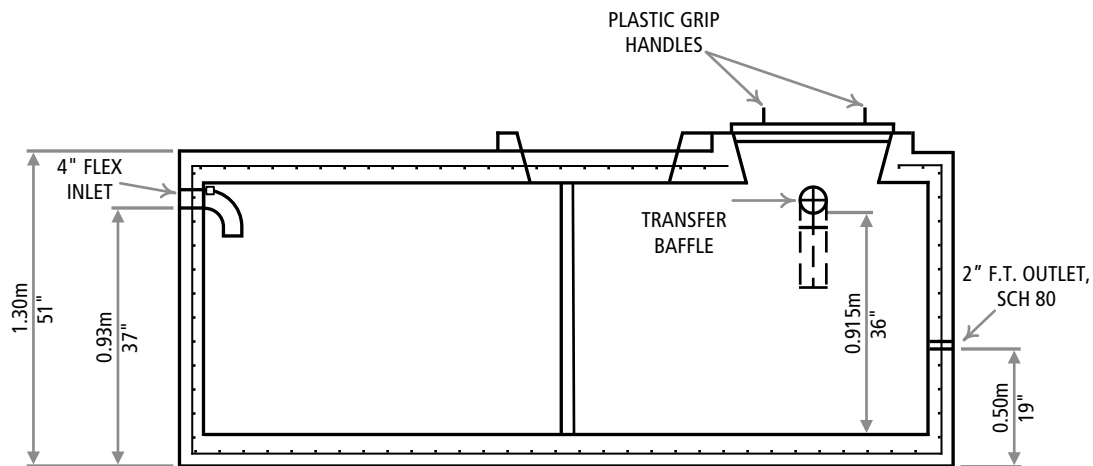

SECTION A-A

TANKS-A-LOT
 onsite water and sewage solutions

1810 Yellowhead Trail N.E.
 Edmonton, AB T6S 1B4

p 780.472.8265
 f 780.478.5699
 tf 800.661.5667

info@tanks-a-lot.com
 www.tanks-a-lot.com

WEIGHT		GROSS/WORKING CAPACITY		EARTH COVER		
10,000 (lbs)		1220 / 751 (gal)		13'-4" (max)		
4,500 (kg)		5546 / 3411 (l)		4m (max)		
MODEL 1220P						
1-PIECE TANK						
LENGTH		WIDTH		HEIGHT		REVISION
10'-6"	3.20m	6'-1"	1.83m	4'-3"	1.30m	2.0