

PLAN

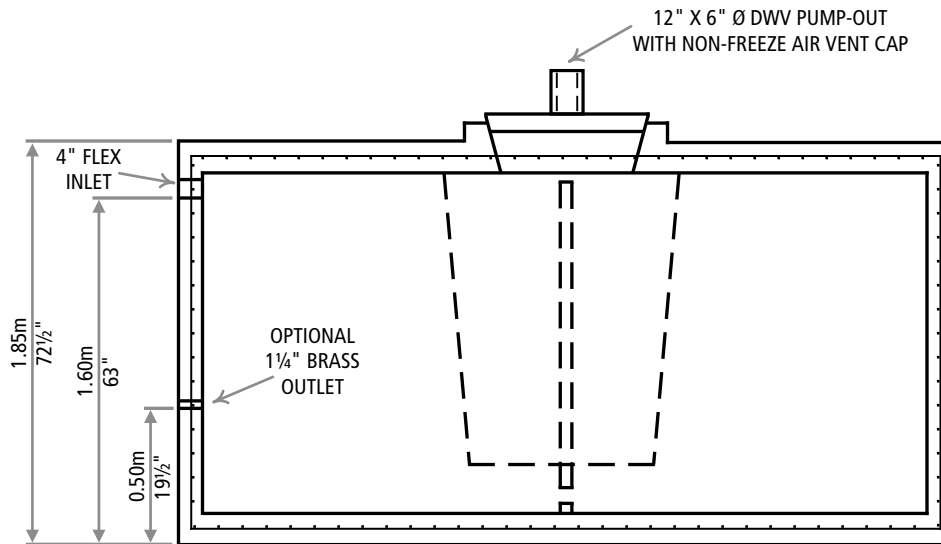

SECTION A-A



1810 Yellowhead Trail N.E.  
Edmonton, AB T6S 1B4

p 780.472.8265  
f 780.478.5699  
tf 800.661.5667

info@tanks-a-lot.com  
www.tanks-a-lot.com

WEIGHT		GROSS/WORKING CAPACITY		EARTH COVER		
16,200 (lbs)		2,200 (gal)		9'-10" (max)		
7,348 (kg)		10,000 (l)		3m (max)		
<b>MODEL 2200H 1-PIECE TANK</b>						
LENGTH		WIDTH		HEIGHT		REVISION
10'-6"	3.20m	7'-7"	2.30m	6'-1/2"	1.85m	2.0