

PLAN

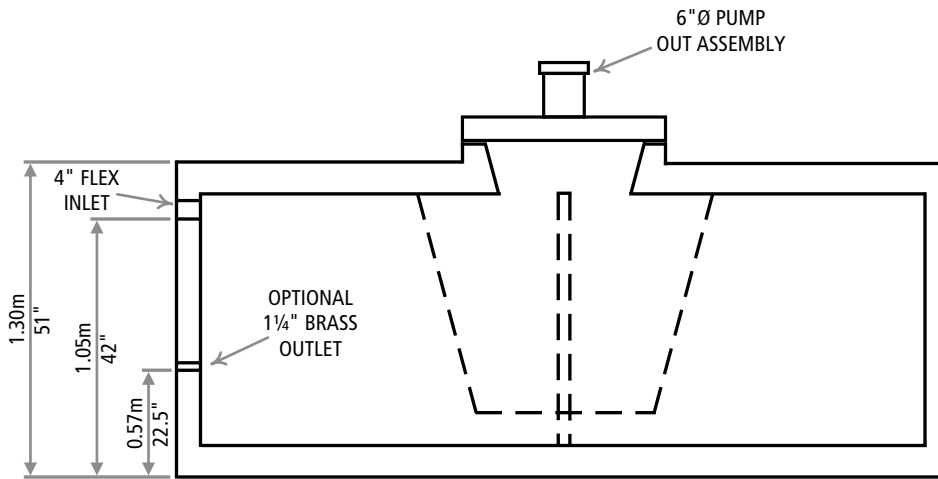

SECTION

\*Note: All measurements are plus/minus 2 inches



1810 Yellowhead Trail N.E.  
Edmonton, AB T6S 1B4

p 780.472.8265  
f 780.478.5699  
tf 800.661.5667

info@tanks-a-lot.com  
www.tanks-a-lot.com

WEIGHT		GROSS CAPACITY		EARTH COVER		
12,120 (lbs)		1,518 (gal)		13'-1" (max)		
5,498 (kg)		6,900 (l)		4m (max)		
<b>MODEL 1518H</b> 1-PIECE TANK						
LENGTH		WIDTH		HEIGHT		REVISION
10'-6"	3.20m	7'-7"	2.30m	4'-3"	1.30m	2.0